



Our Sponsor: Cibus is a leader in gene edited productivity traits that address critical productivity and sustainability challenges for farmers such as disease and pests.

The Problem: Cibus uses SBS one-well plates filled with plant media in their production process. Currently, filling and storing these plates is dangerous, labor intensive, and time-consuming. Our system eliminates all three of these problems.

Deliverables:

- Design documentation of the filling sub- system
- Physical prototype of the filling sub-system

Stretch goal:

- Design documentation of the storage system
- Physical prototype of the storage system

System Description

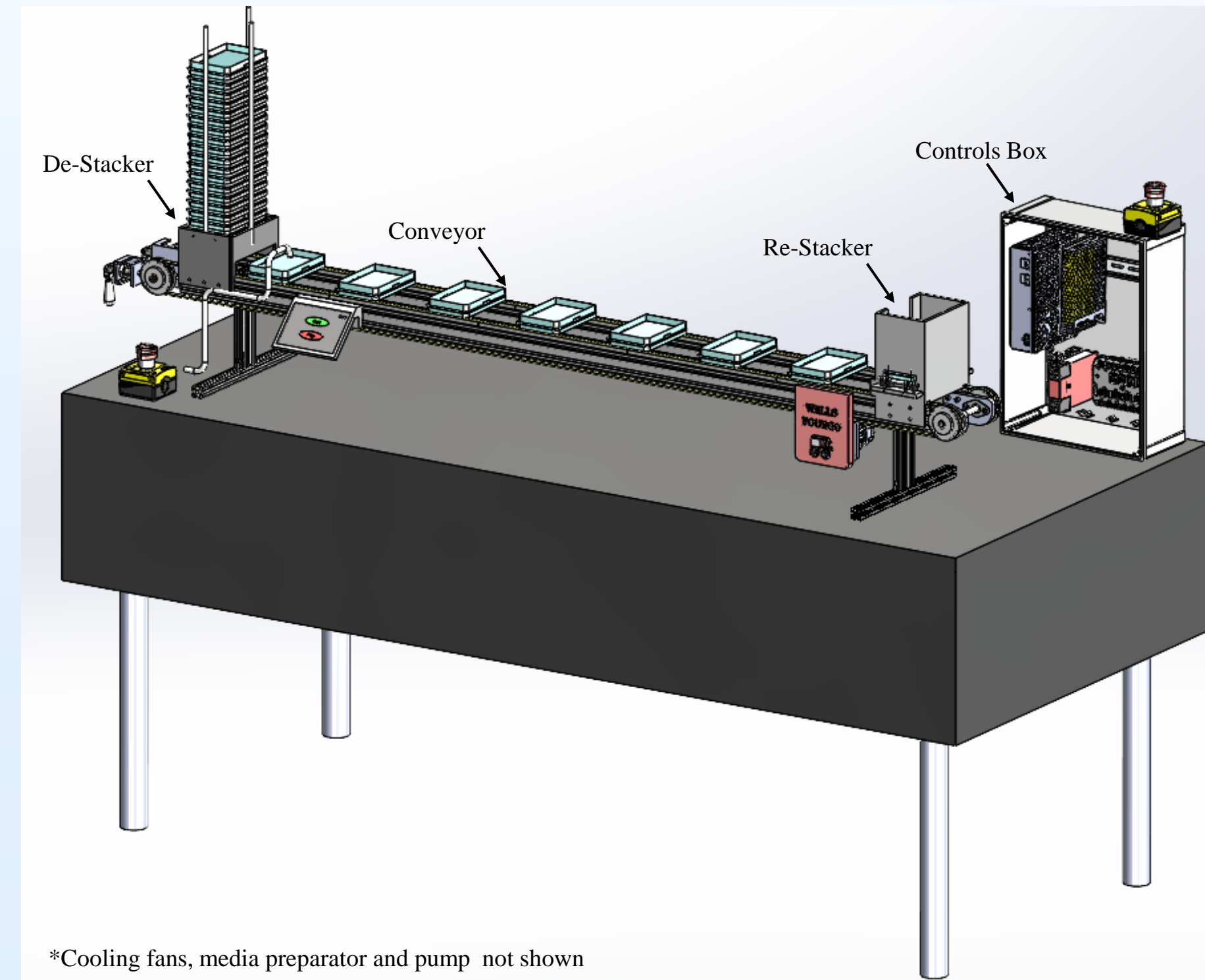

Operation:

This system is designed to be fully autonomous with continuous throughput. An operator loads plates into the machine and removes them from the other end. Plates are cooled in transit to eliminate the need for storage.

Architecture:

A mechanical housing de-stacks the plates onto the conveyor belt where a capacitive sensor detects the plate and triggers the dispensing of media. Cooling fans rapidly cool the media before the plates are re-stacked for storage. Linear actuators are used to lower and lift plates from the input/output housings, respectively. A safety relay monitors two e-stop buttons and controls power to the motors for emergency situations.

Design Approach:

Using a modular approach, each subsystem was designed, prototyped and tested using 3D printing for rapid iteration. Once verified, each subsystem was integrated into the device for further testing.

Meet the Team



Troy Robinson
Team Lead



Rhold Angelo Flauta
Manufacturing Lead



Kazem Shawwa
Electrical Lead



Derek Crowley
Design Lead

Concept Design & Prototyping

De-Stacker

A sliding plate actuated by a cam slides under the lid of the plate. This retains the stack while the base of the plate is lowered. Plates ride along the conveyor on the lid of the plate below. De-stacking and de-lidding in one operation.

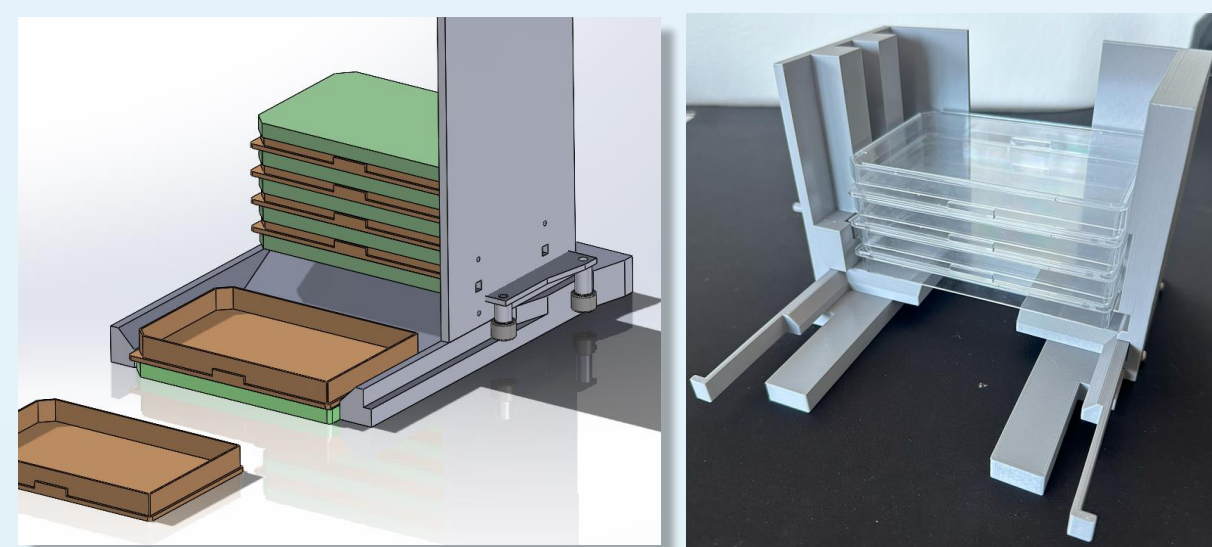

Re-Stacker

Plates are pushed upwards into the stack. The spring loaded pawls are deflected before clicking back into place. The stack of plates is lowered and rests on the pawl.

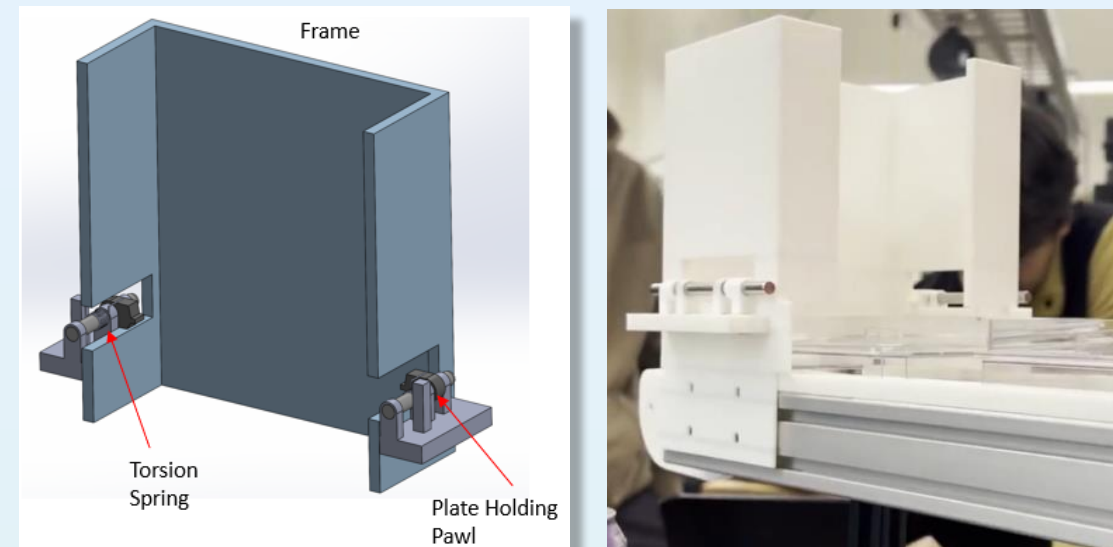

Conveyor

The conveyor uses two belts to move plates along the frame. A quick release tensioner allows for easy cleaning under the belts. A keyed shaft maintains timing between the belts.

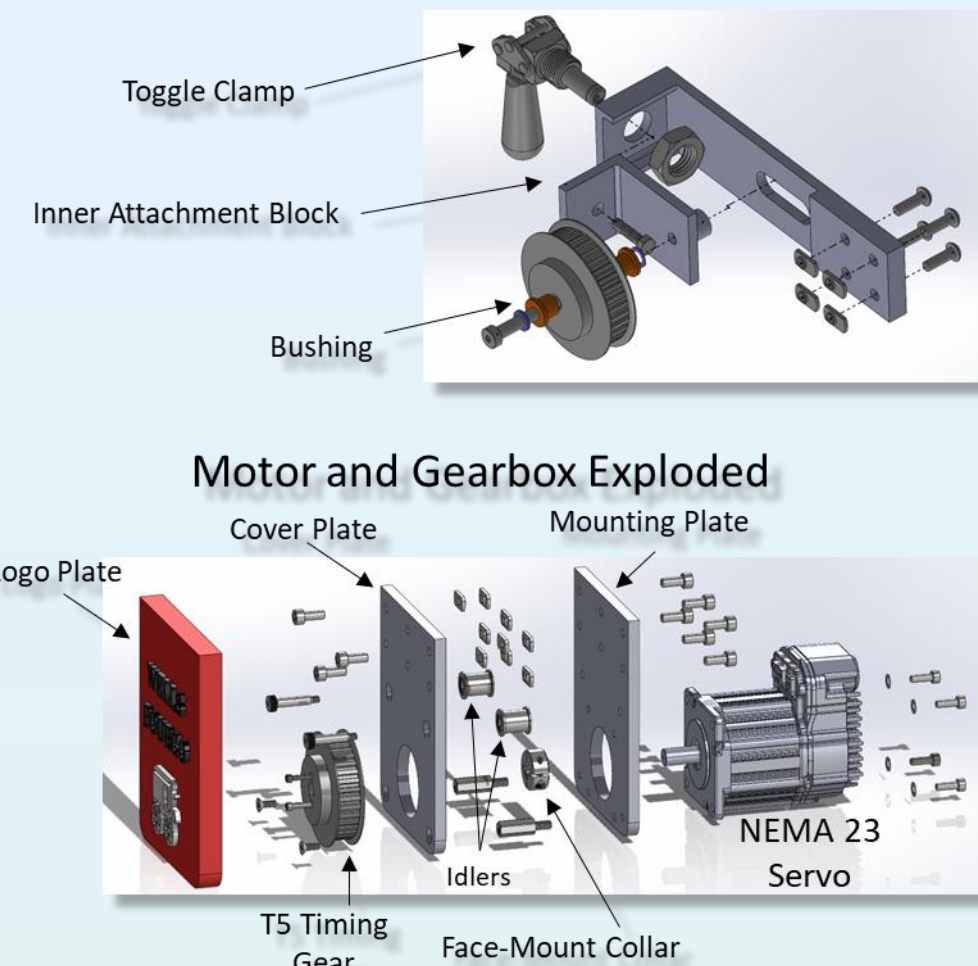

Manufacturing

Equipment Used:

- Lathe
- Vertical mill
- Water jet
- 3D printers
- Band Saw

Techniques Used/Learned:

- Drilling + Tapping
- Facing + Turning
- Broaching
- Tuning print settings and supports
- Design for printability

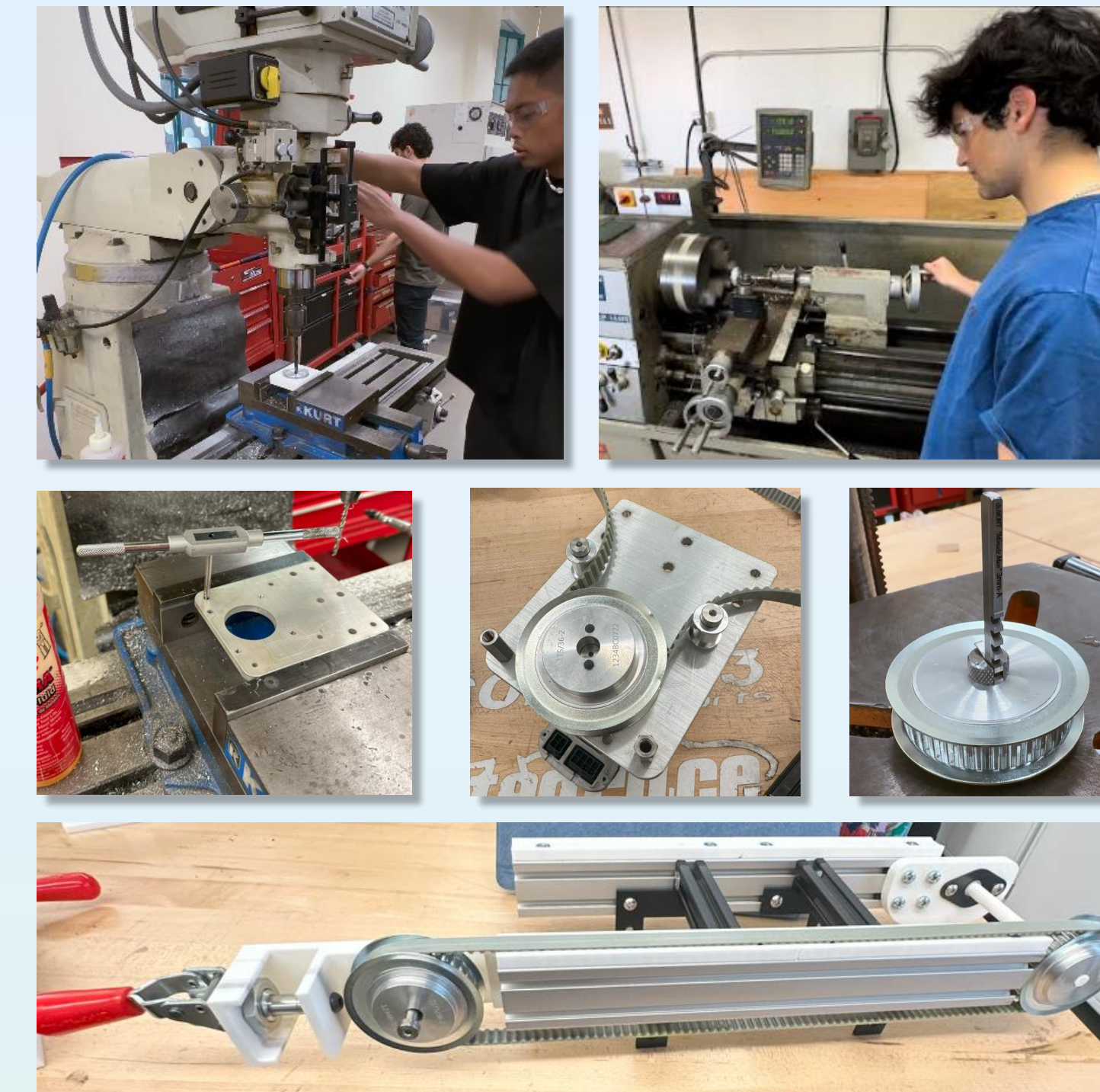

Testing

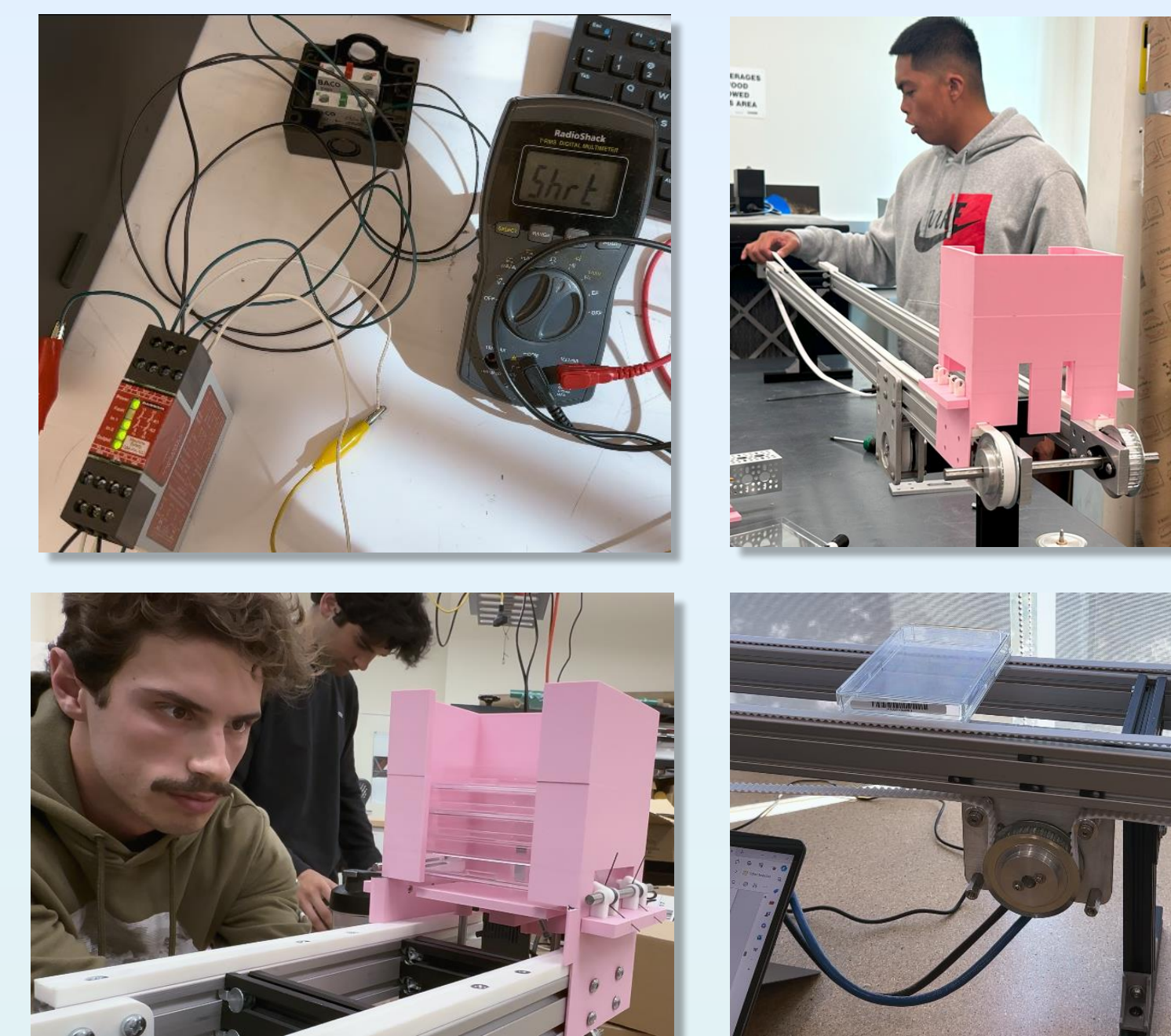

System Level Diagram

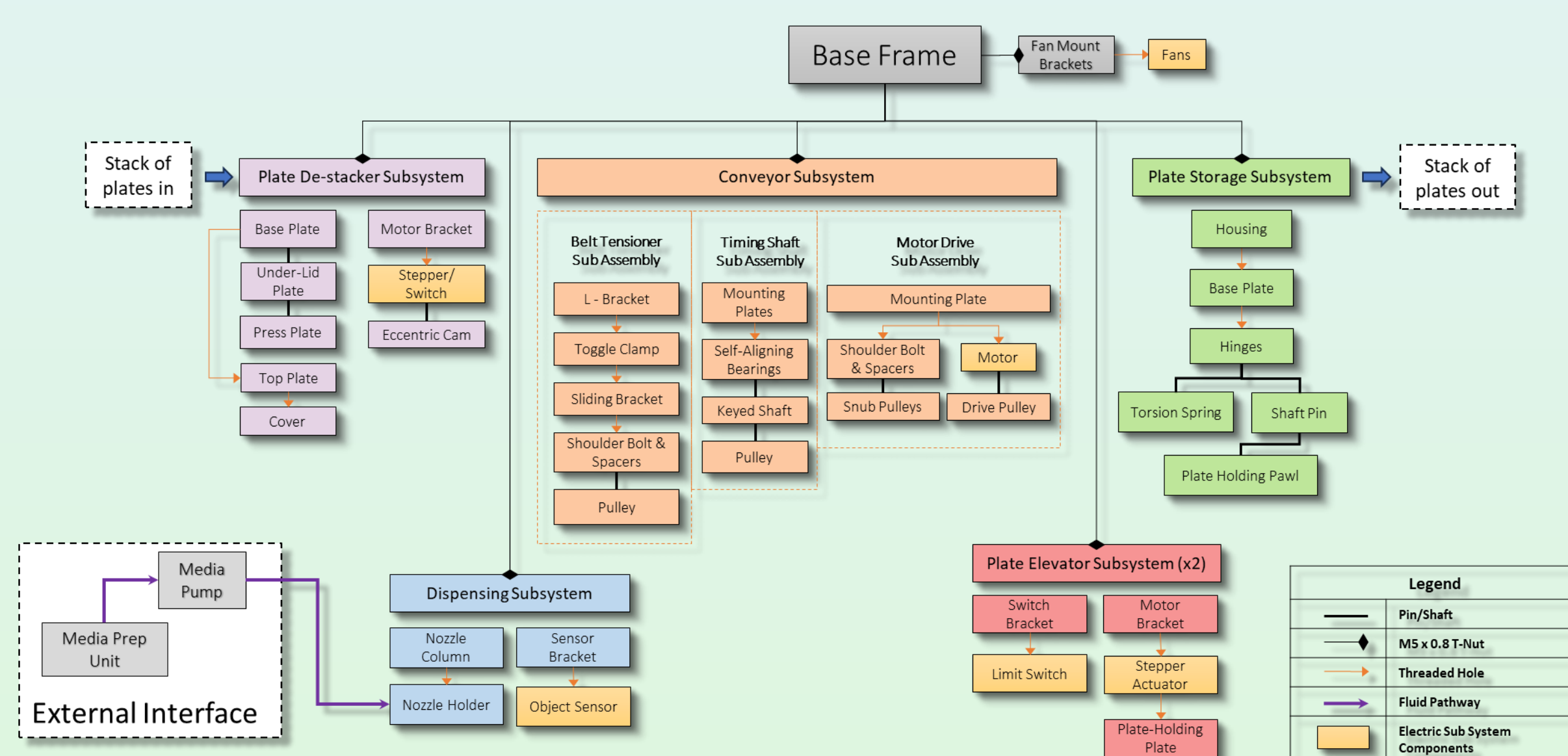

Electrical Schematic

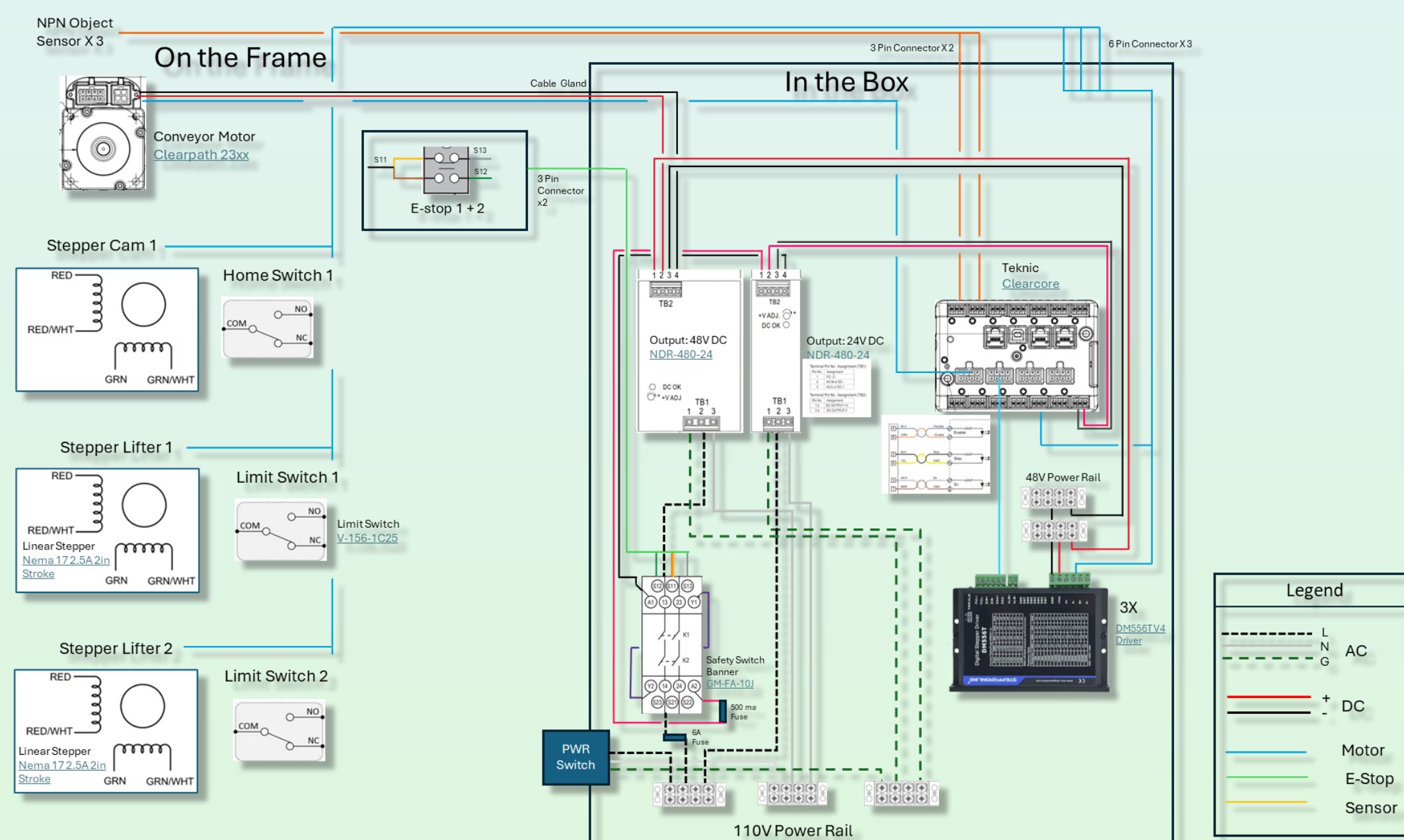

Software Flow Chart

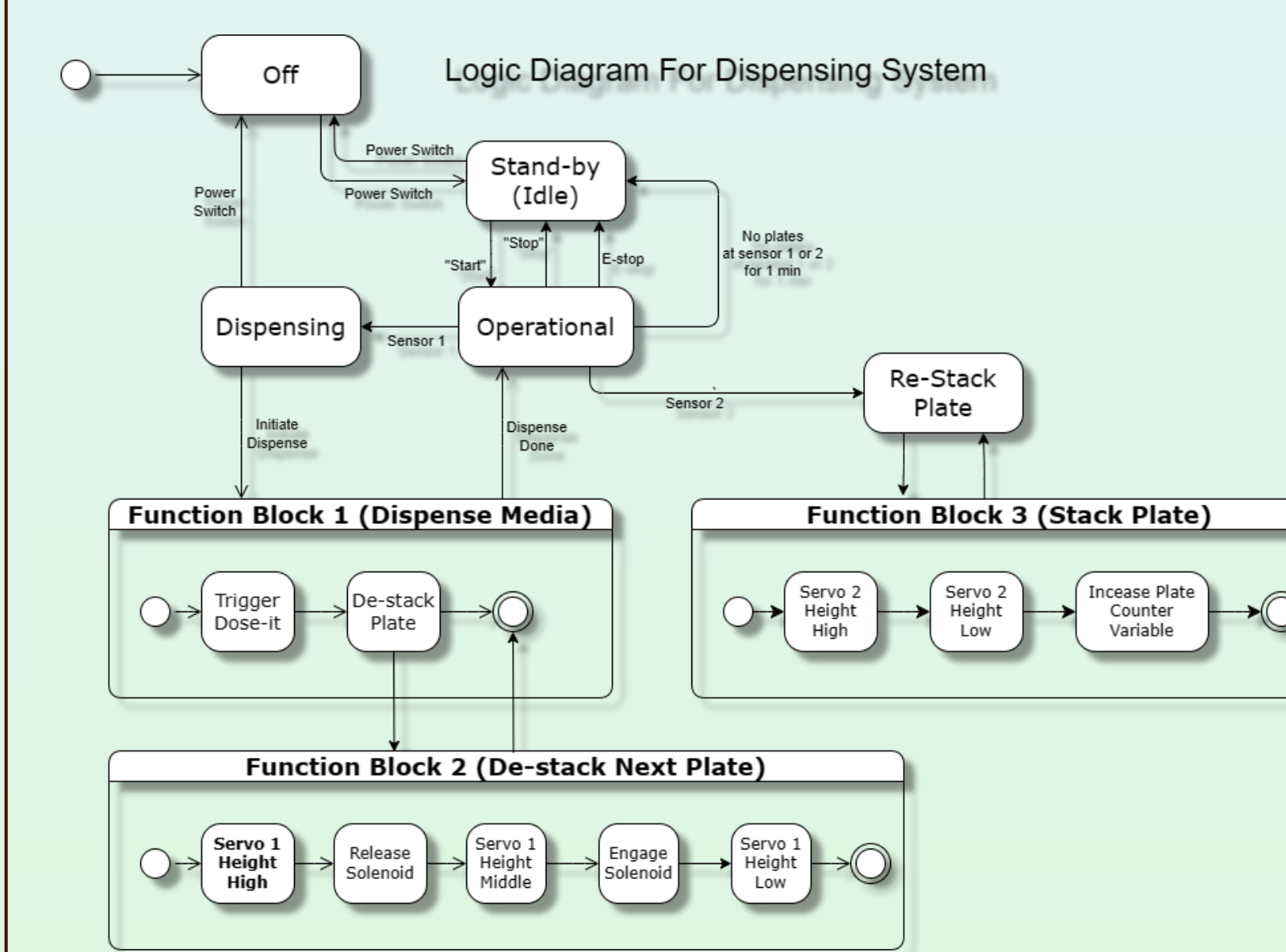

Project Management

Scope, budget and risk were constantly monitored throughout the project. This was achieved using a Gantt chart, trackers, and bi-weekly sprint planning.

Budget Allotted:	\$10,000
Planned Spend:	\$3500
Total Spend:	\$4500

Acknowledgements

We would like to thank the following individuals for their contributions throughout the program.

- | | |
|---------------------|------------------------------|
| - Cibus US LLC | - San Diego State University |
| - Chuck Tweedy | - Dr. Scott Shaffar |
| - Andrew Walker | - Mike Lester |
| - Greg Gocal, PhD | - Dr. John Abraham |
| - Rosa Cheuk Kim JD | - Louisa Burrus |
| - Robert Bracamonte | |