



Electro-Mechanical Continuously Variable Transmission

Team Electric Makos



Final Design

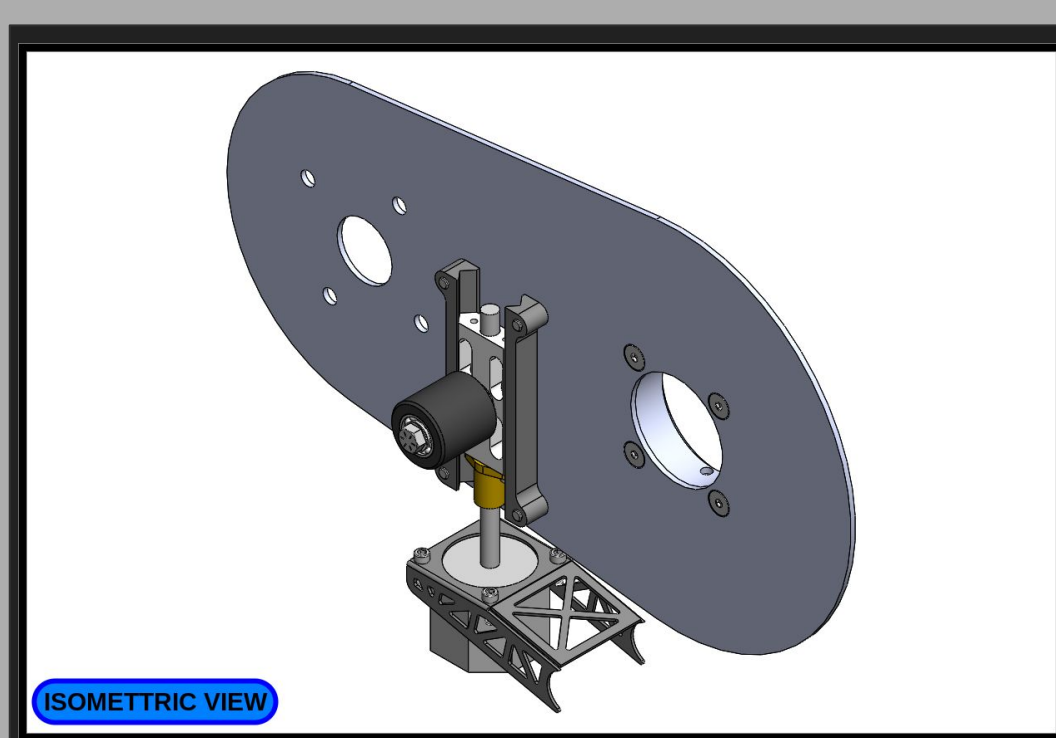
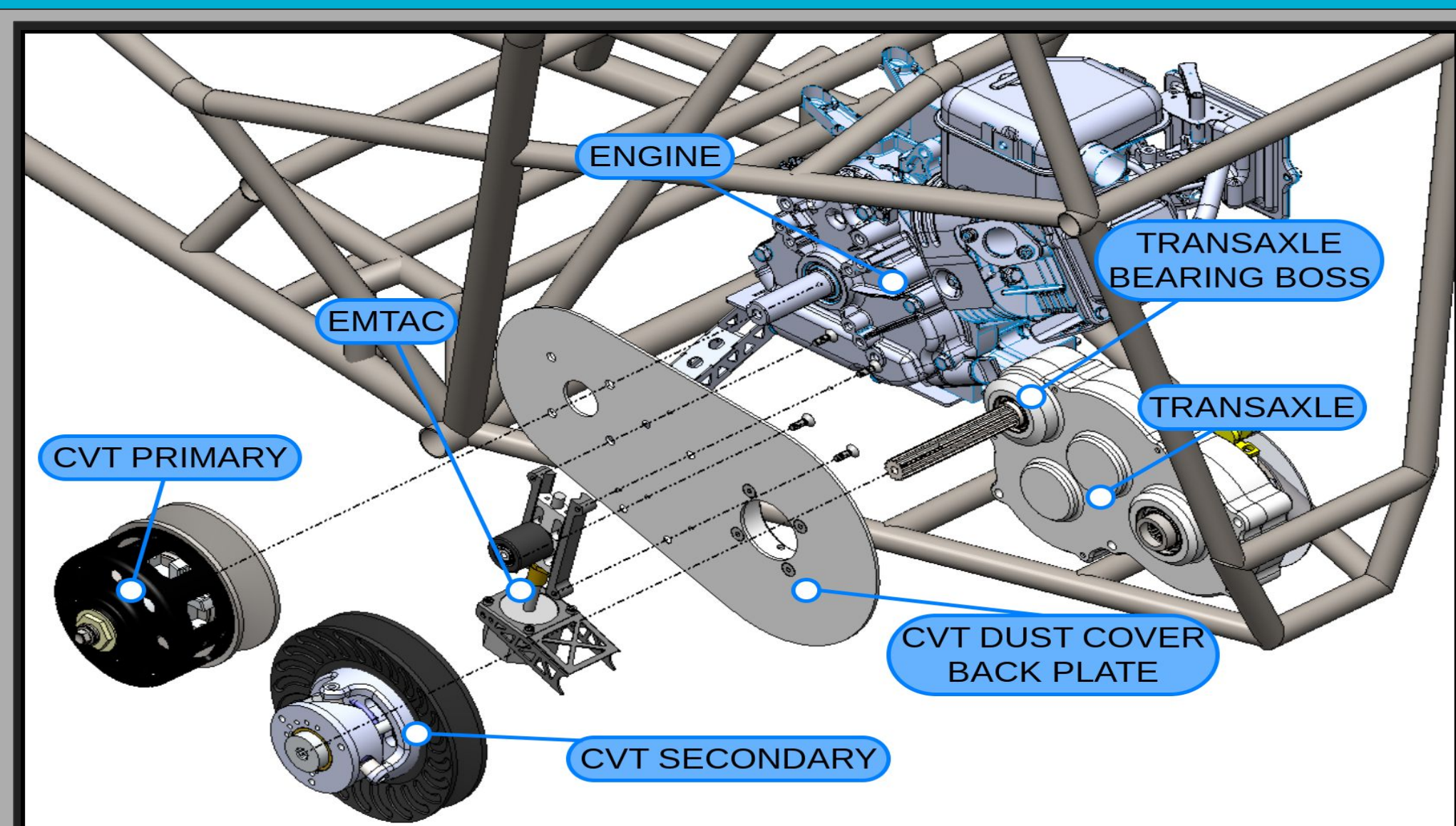

Project Overview

The goal of the Electro-Mechanical Continuously Variable Transmission project is to develop a system that can electro-mechanically shift the GX9 CVT on the Aztec Baja Racing car. On its own, the GX9 CVT experiences shift delay from high to low ratios. The team designed an electro mechanical transmission assist component (EMTAC) which is capable of influencing CVT ratio through belt tension. A stepper motor and power screw are used to linearly actuate a pulley, allowing belt tension to be adjusted. The system is controlled electronically and utilizes hall effect sensor input.

Team Members

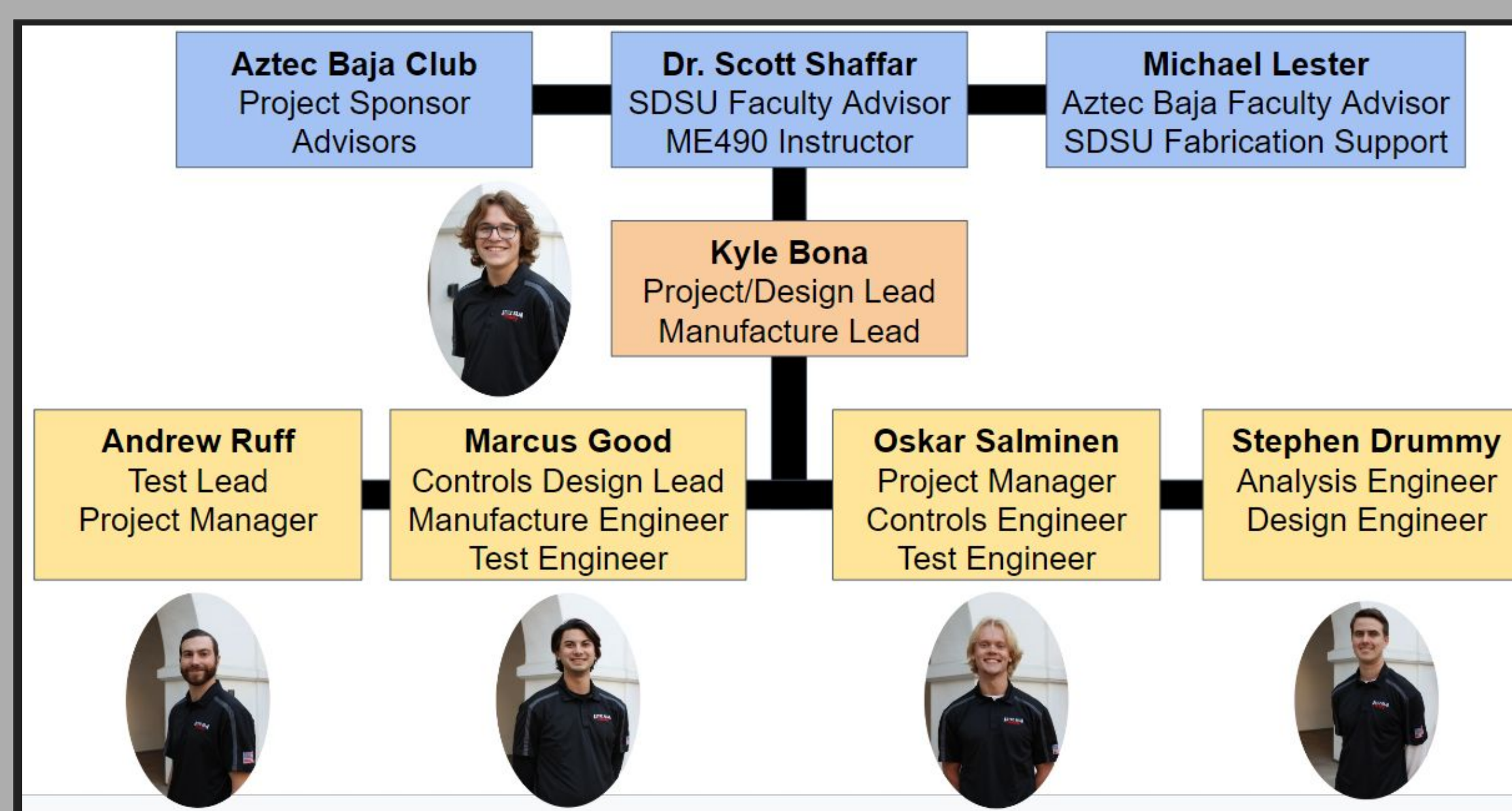

Control System

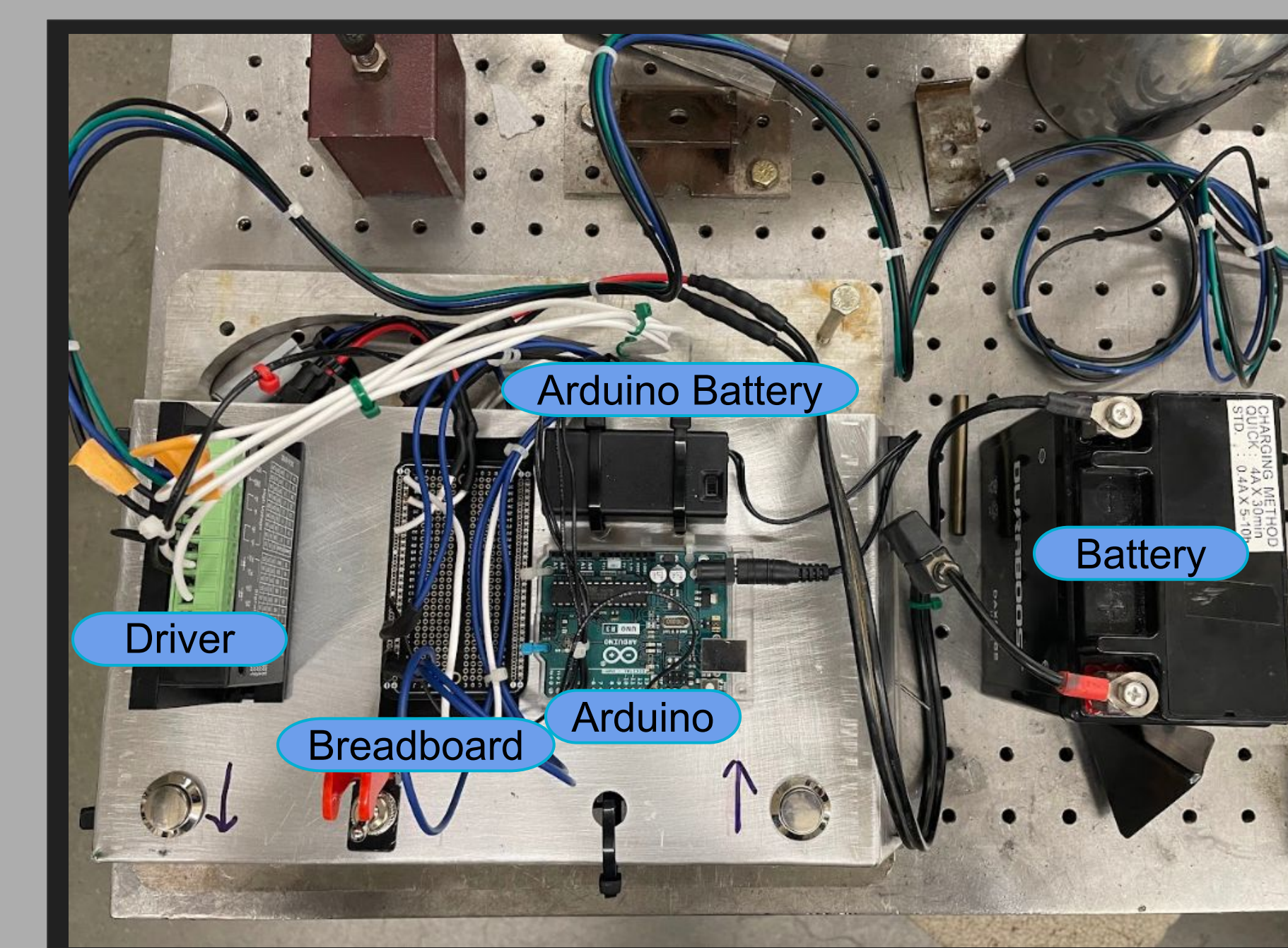
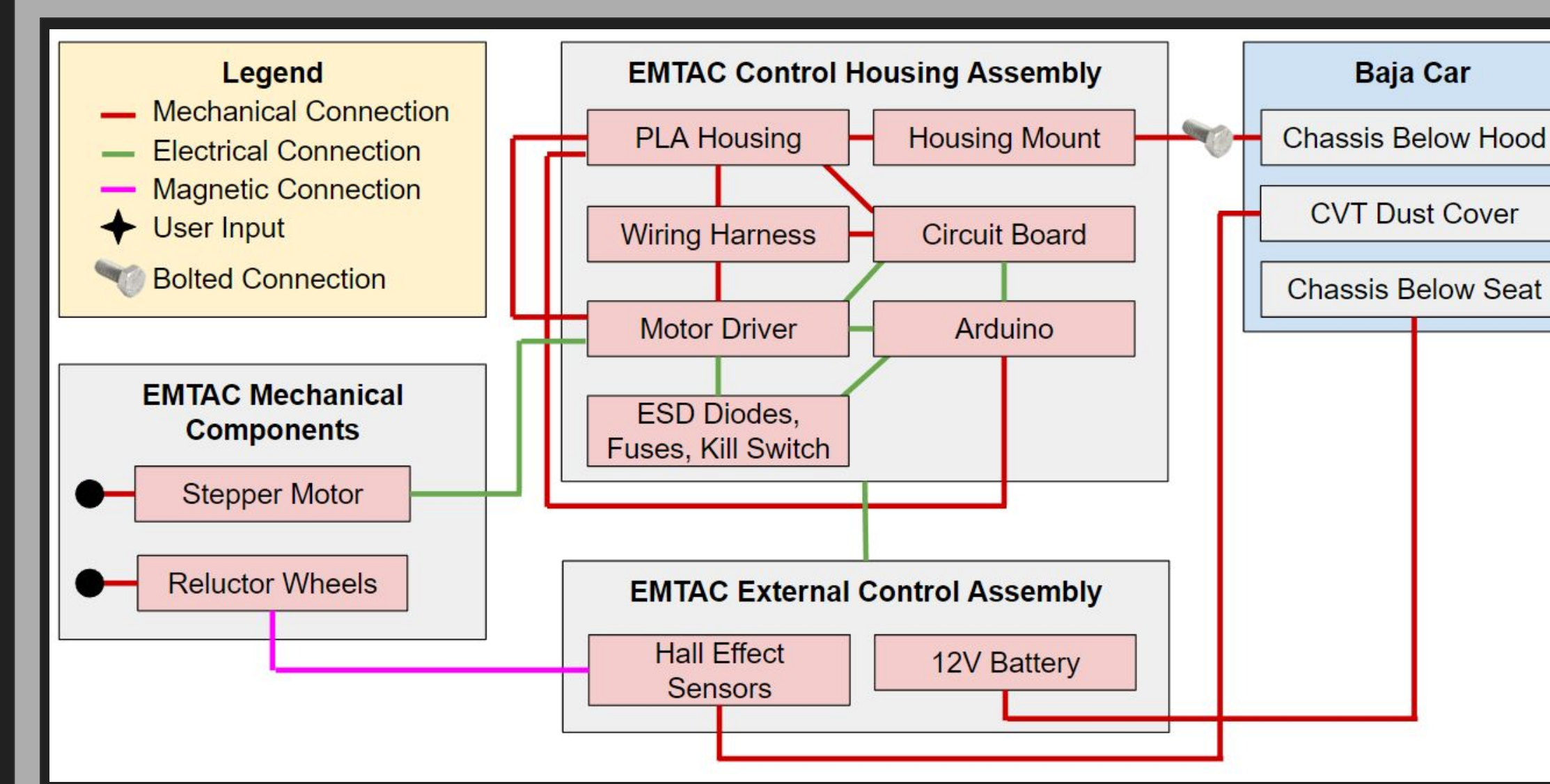

Testing

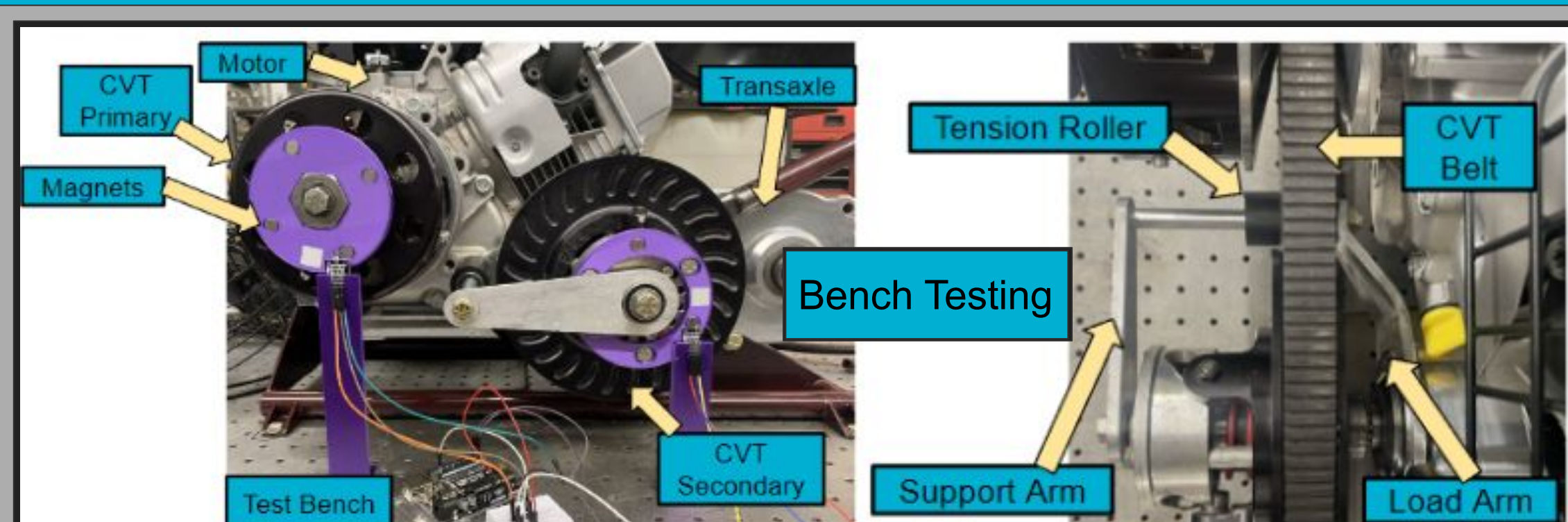

Acknowledgments

The electro-mechanical CVT project would not have been possible without the contribution of our sponsor and advisors. We would like to thank our instructor Dr. Shaffar, faculty advisor Michael Lester, and Baja President Manuel Aldana. Project funding was made possible by Aztec Baja Racing. Furthermore, we would like to thank the staff that made Senior Design Day possible.

System Level Diagram

