

## Project Overview

**Problem Statement:**  
The project description is to design a powered hiking prosthetic foot solution for Quality of Life Plus, a national organization that aims to improve the lives of disabled veterans and first responders. Our team was challenged to design an advanced prosthetic capable of going on long hiking and hunting expeditions in inclement weather.

**Need:**  
This project is designed to assist Nick Kimmel, a Marine who sustained injuries in duty leading to amputation of both legs above the knee and one arm above the elbow. The prosthetic device shall provide powered assistance to one leg for going up and down hills so that Nick can engage in his usual physical activities.

## Team Members

### ME:



Mathew Blake  
ME Team Lead



Garrett Grommes  
Design Engineer

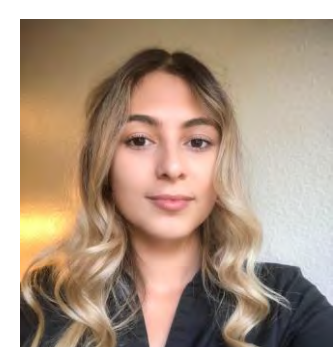

Susana Arellano  
Design Engineer

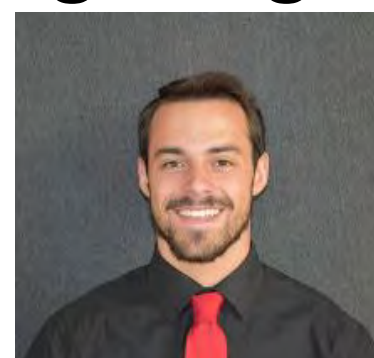

Zachary Brueggeman  
Manufacturing Engineer

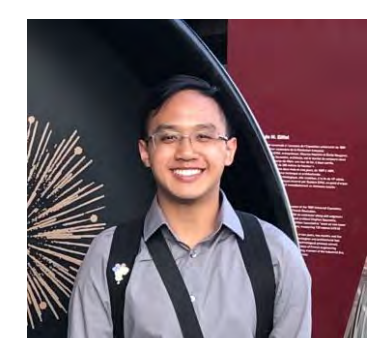

Marc Anthony Do  
Quality/Test Engineer

### ECE:

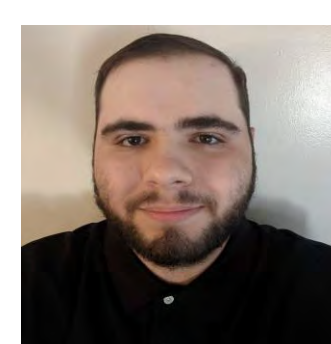

Justin Killam  
ECE Team Lead



Nassar Almarshoud  
EE Project Lead

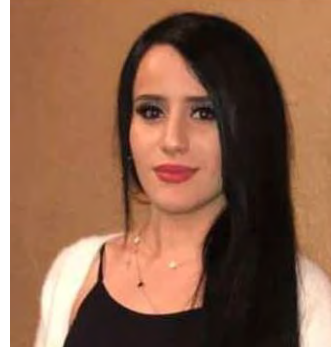

Dina Bastros  
Safety Engineer



Jarel-Johnson Macanas  
Design Engineer



Sony Shosani  
Design Engineer

## Mechanical Design

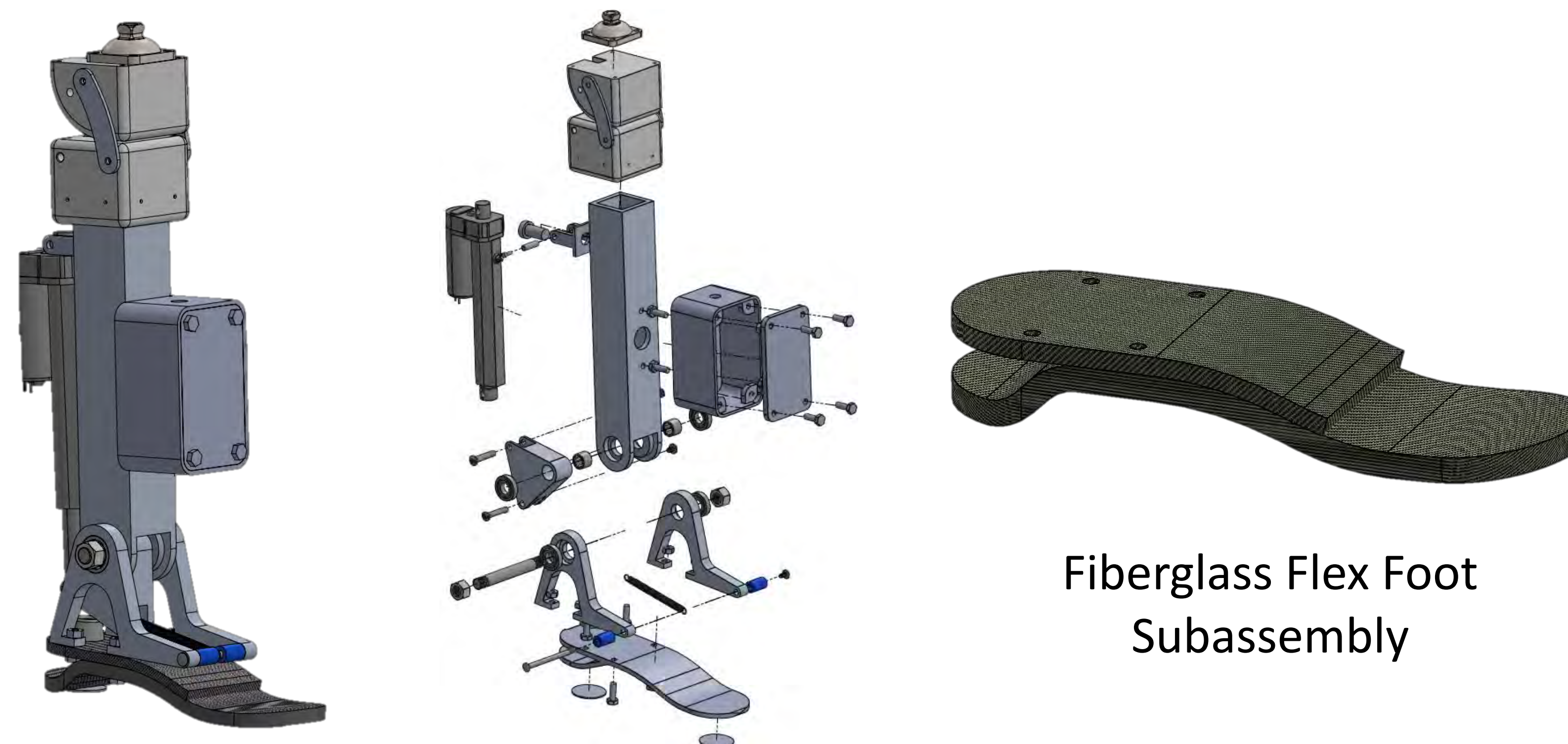

Fiberglass Flex Foot Subassembly

## Electrical Design

- Complete Electronics Schematic Diagram (right)
- PCB Design V.1 (below)

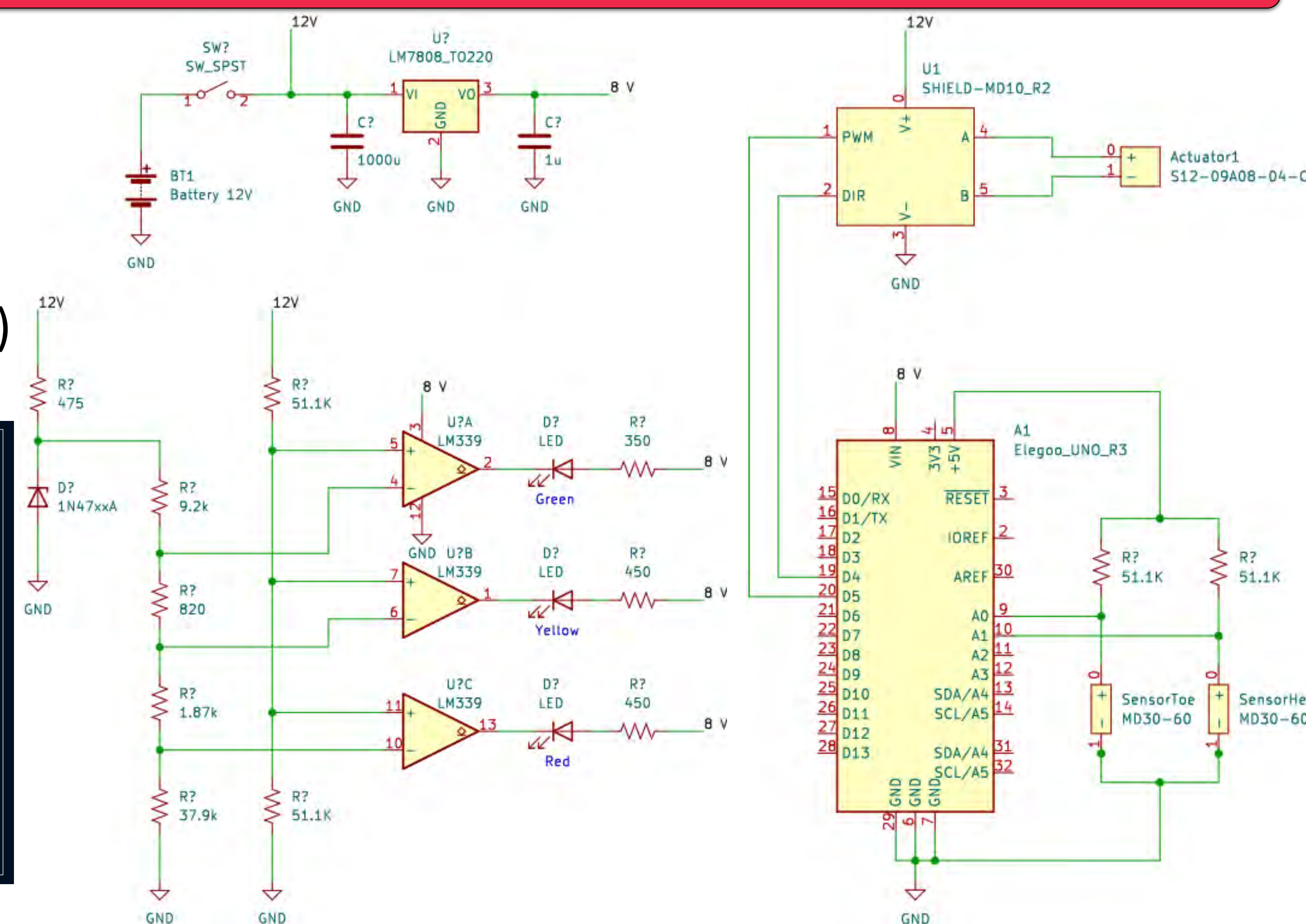
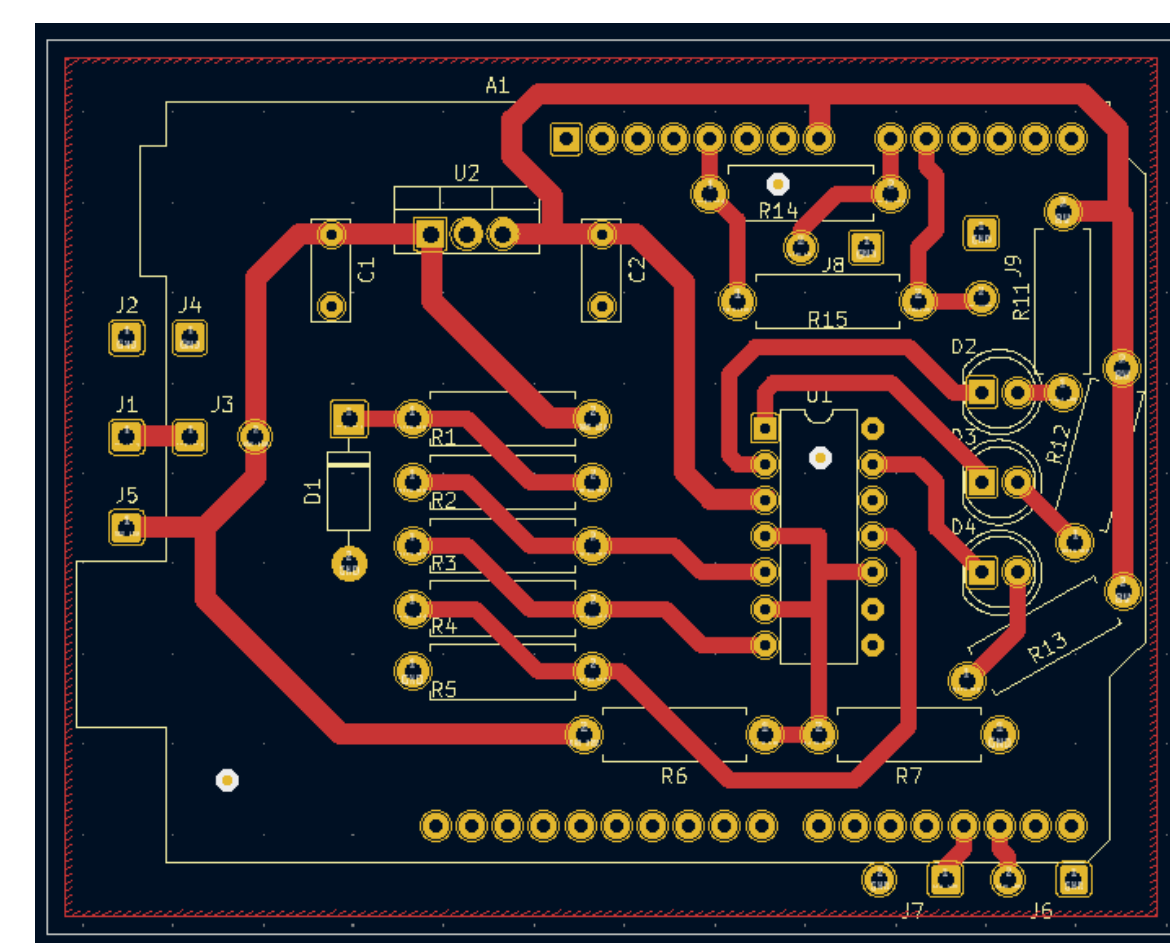

## Testing

Testing the system's range of motion with the extension of the actuator and its location on the pylon.

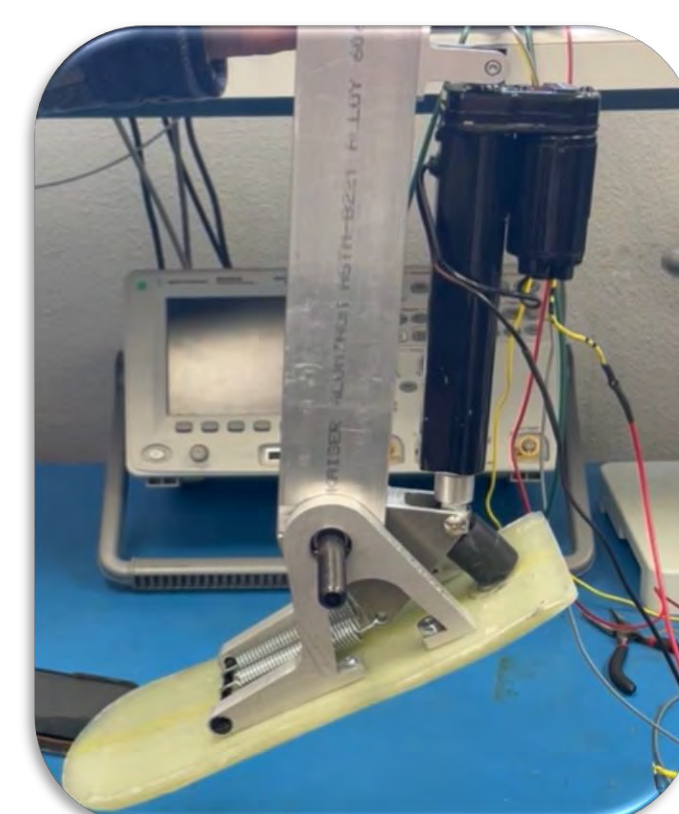

When contracted, foot is in plantar flexion.



When extended, foot is in dorsiflexion.

Battery Voltage vs Time Under 3A Constant Load

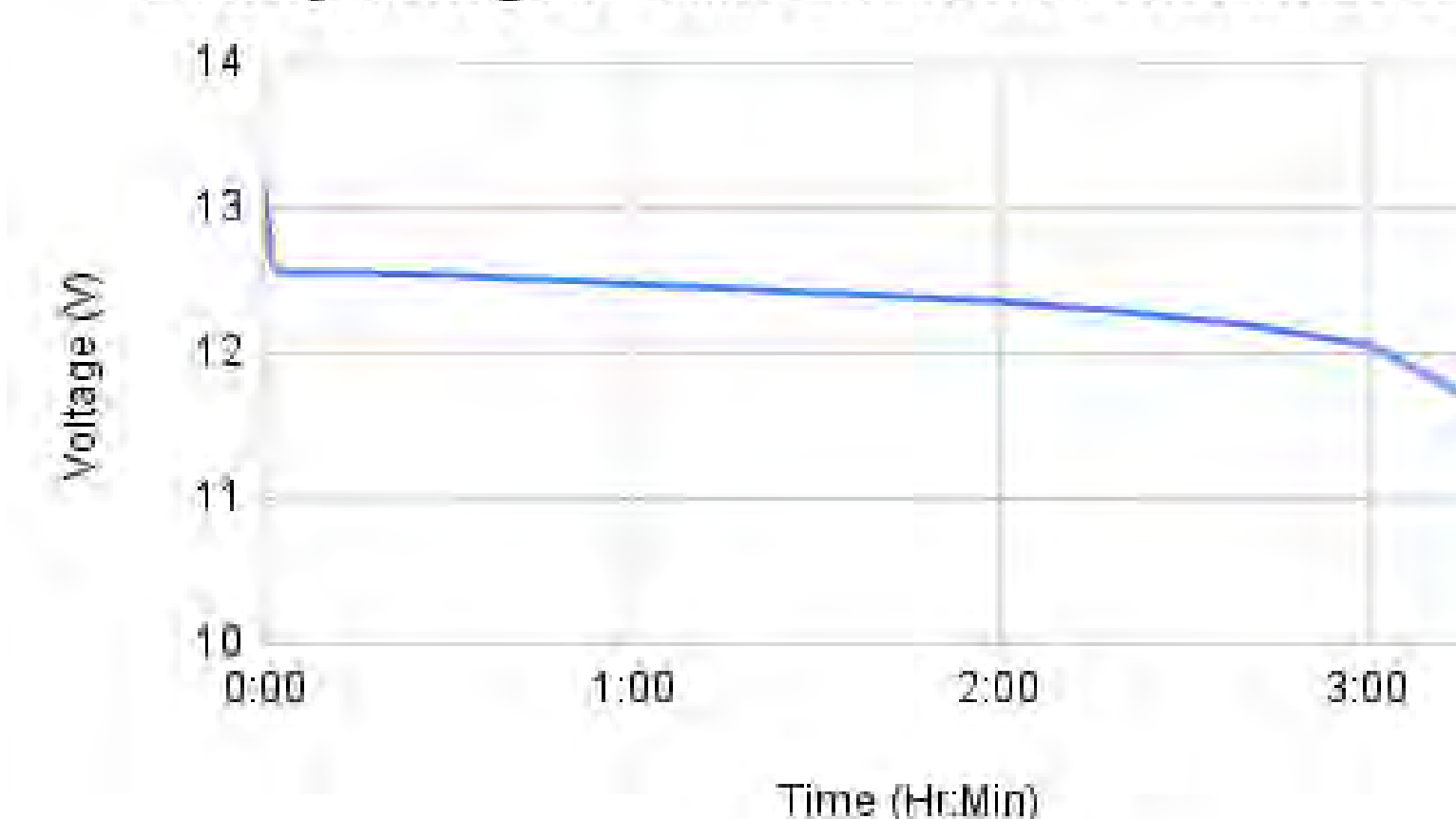

Testing the system's battery under a 3A constant load, we found the battery lasted approximately 3 hours, sufficient for the average length hike.

## Final Product

Assembled System With Electronic Housing

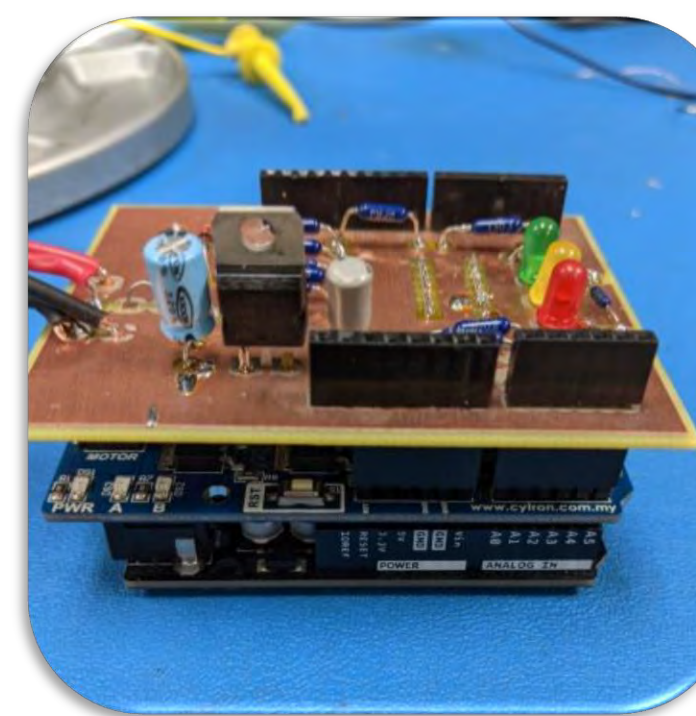
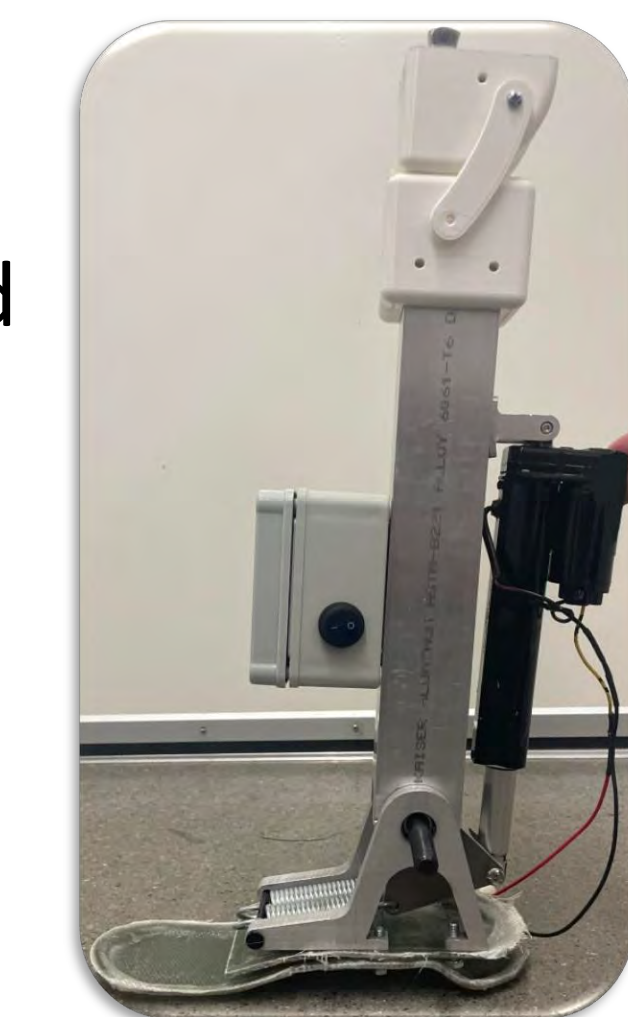

Assembled and Soldered Boards

## Prototyping

- Initial prototype tested with a bypass (right).
- First iteration of molded fiberglass foot (below).

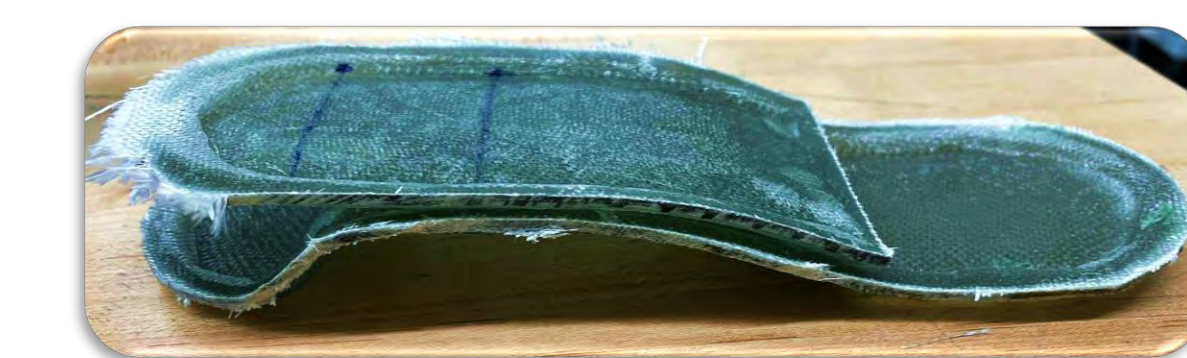

## Design Analysis

Major structural parts simulated under 250 lbs. of loading to account for the weight of the user and any additional gear they may carry.

Foot Assembly:

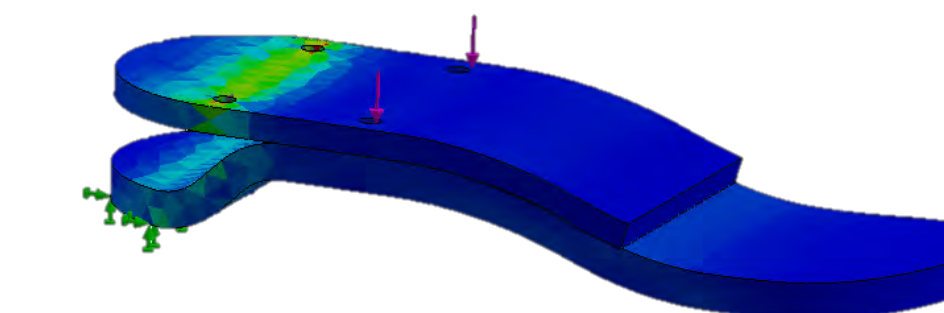

Brackets:

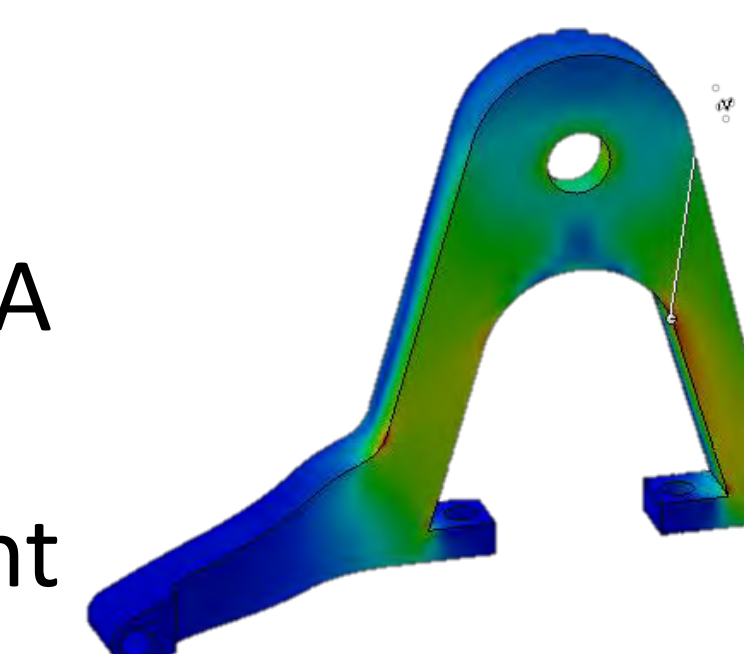

Pylon:

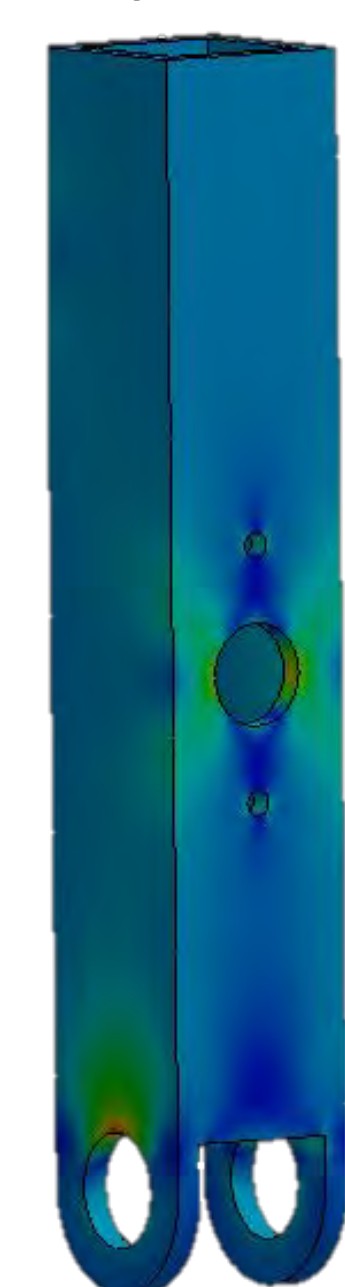

All were under yield strength and showed no serious deformation.