



# Enclosure Door Handles For Industrial Applications

## Project Overview

Solar Turbines specializes in turbo-machinery for energy generation. Often times, this machinery is protected inside of a ventilated enclosure. The ventilation system creates a pressure differential between the outside atmosphere and inside of the enclosure. This requires technicians to shut off the ventilation system prior to opening the enclosure doors. Solar Turbines tasked the team with creating system to simplify the opening and closing of these pressurized doors.

The team designed a mechanism that uses leverage as a means of delivering pull/push forces to open and close the doors within real operating conditions. The mechanism is fully mechanical, ergonomic, and safe for technicians.

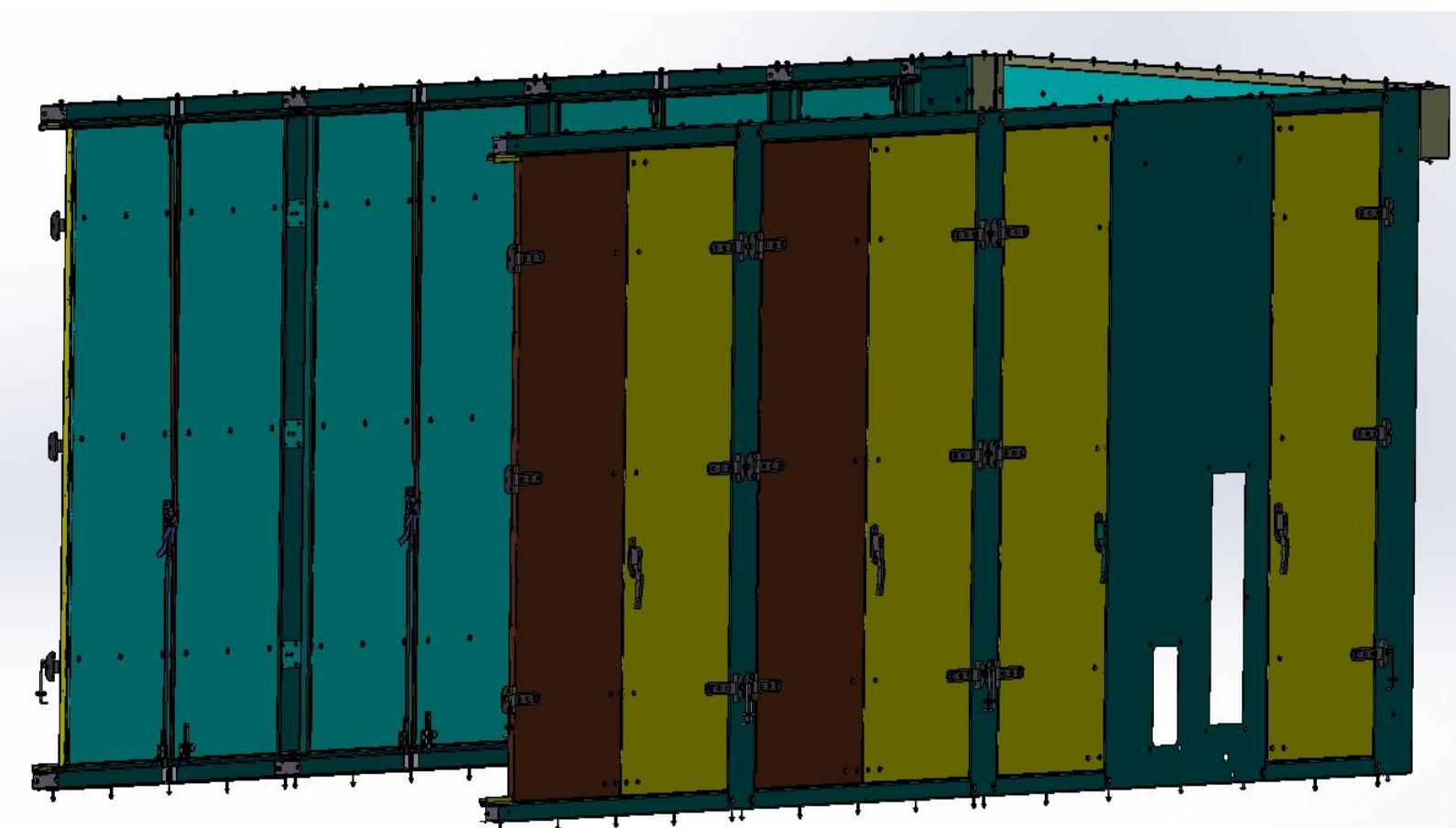

## Engineering Team



Top Row (Left to Right): Cesar Tellez Ornelas, Nhat Hoang, William Ramirez  
Bottom Row (Left to Right): Abel Napoleon, Tung Le

## Main Components

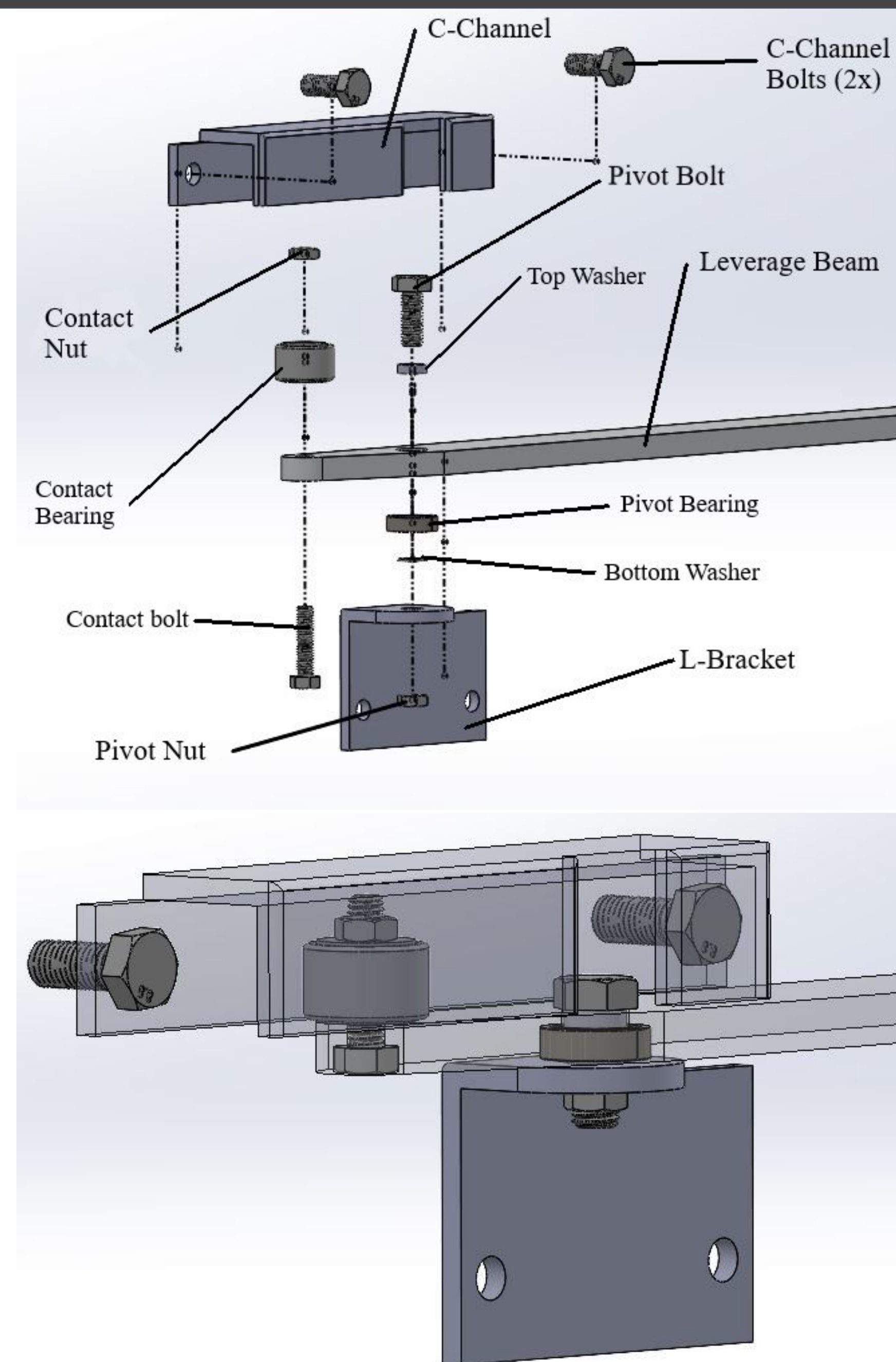

## System Level Diagram

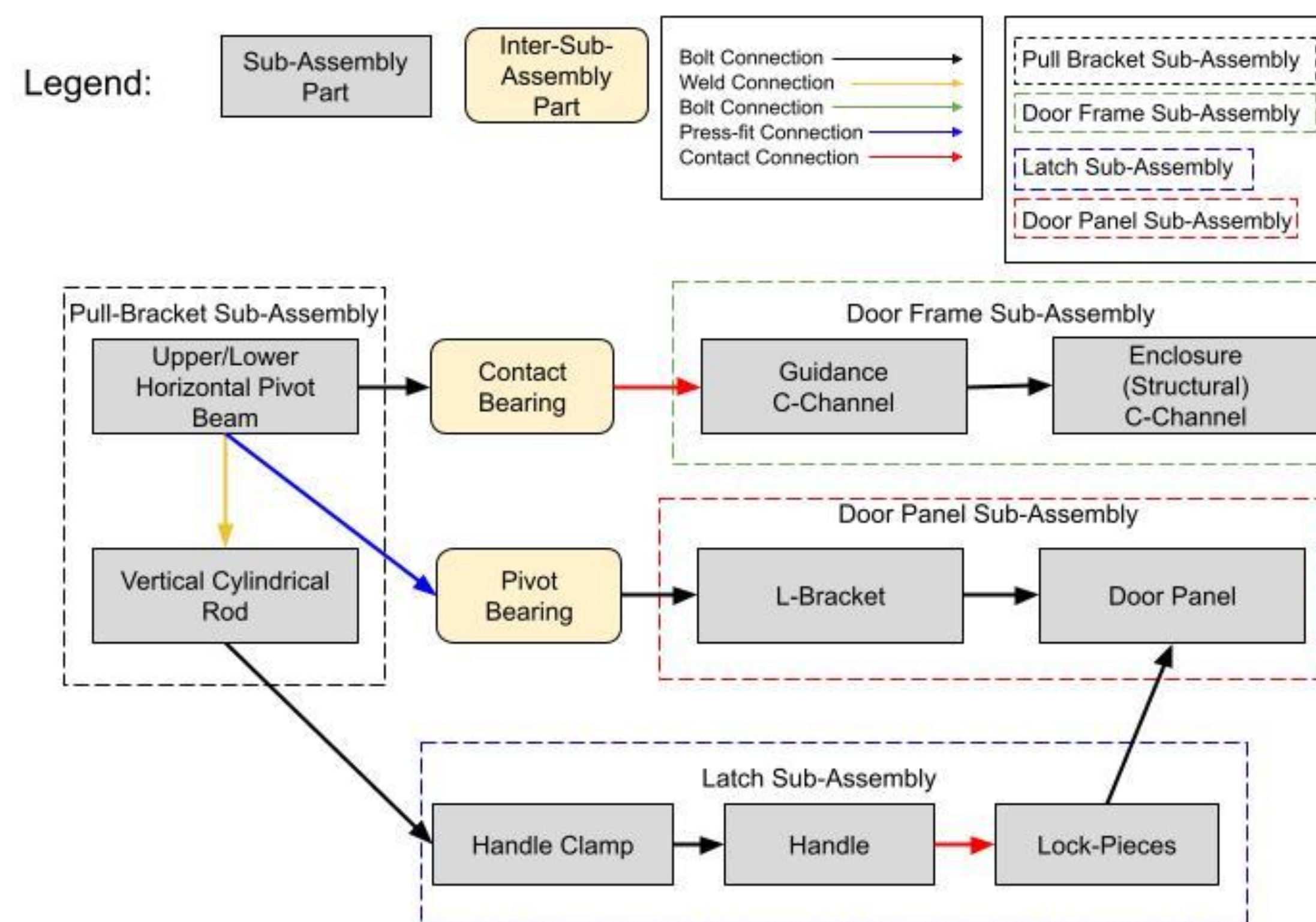

## Testing Data

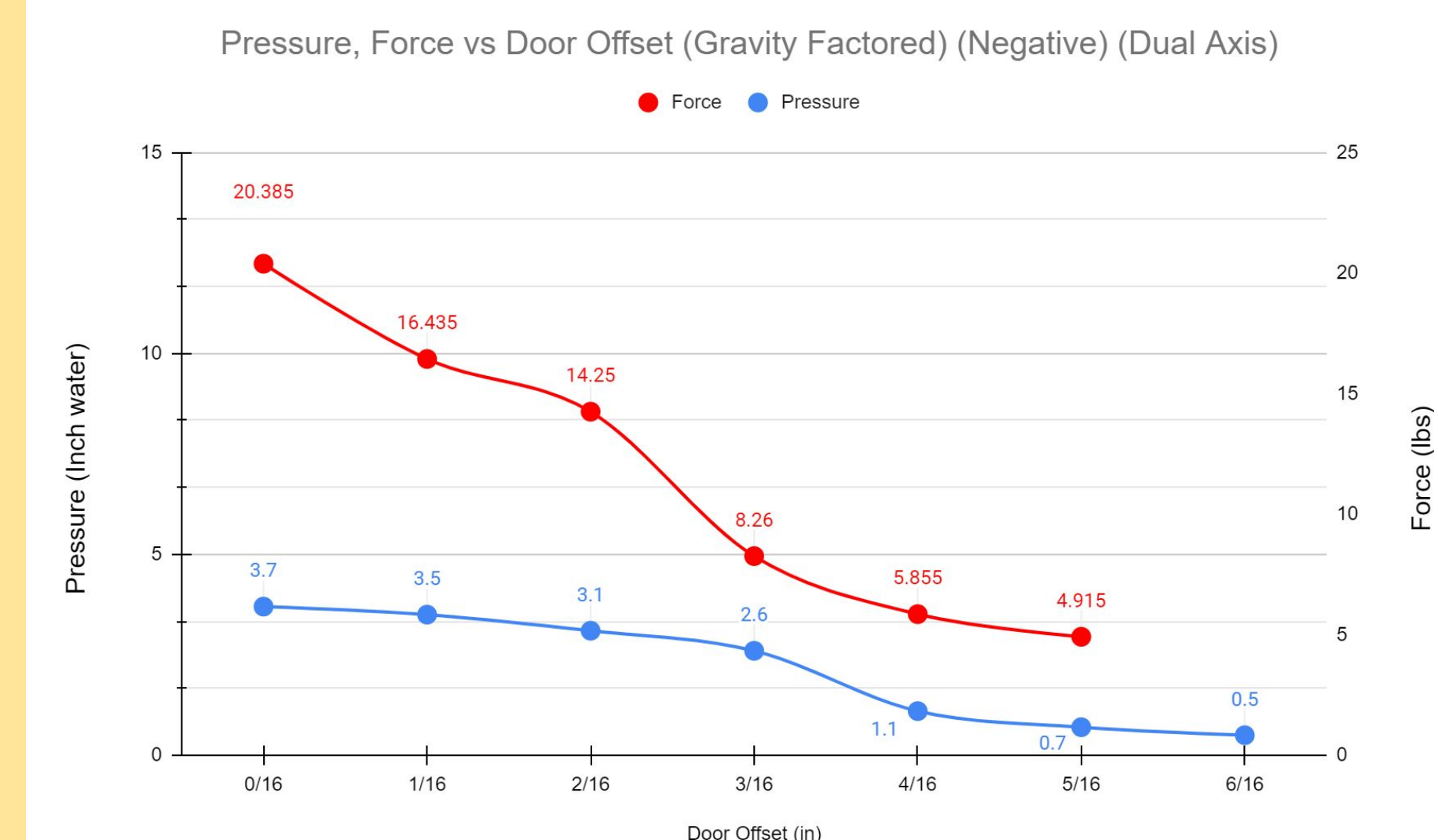
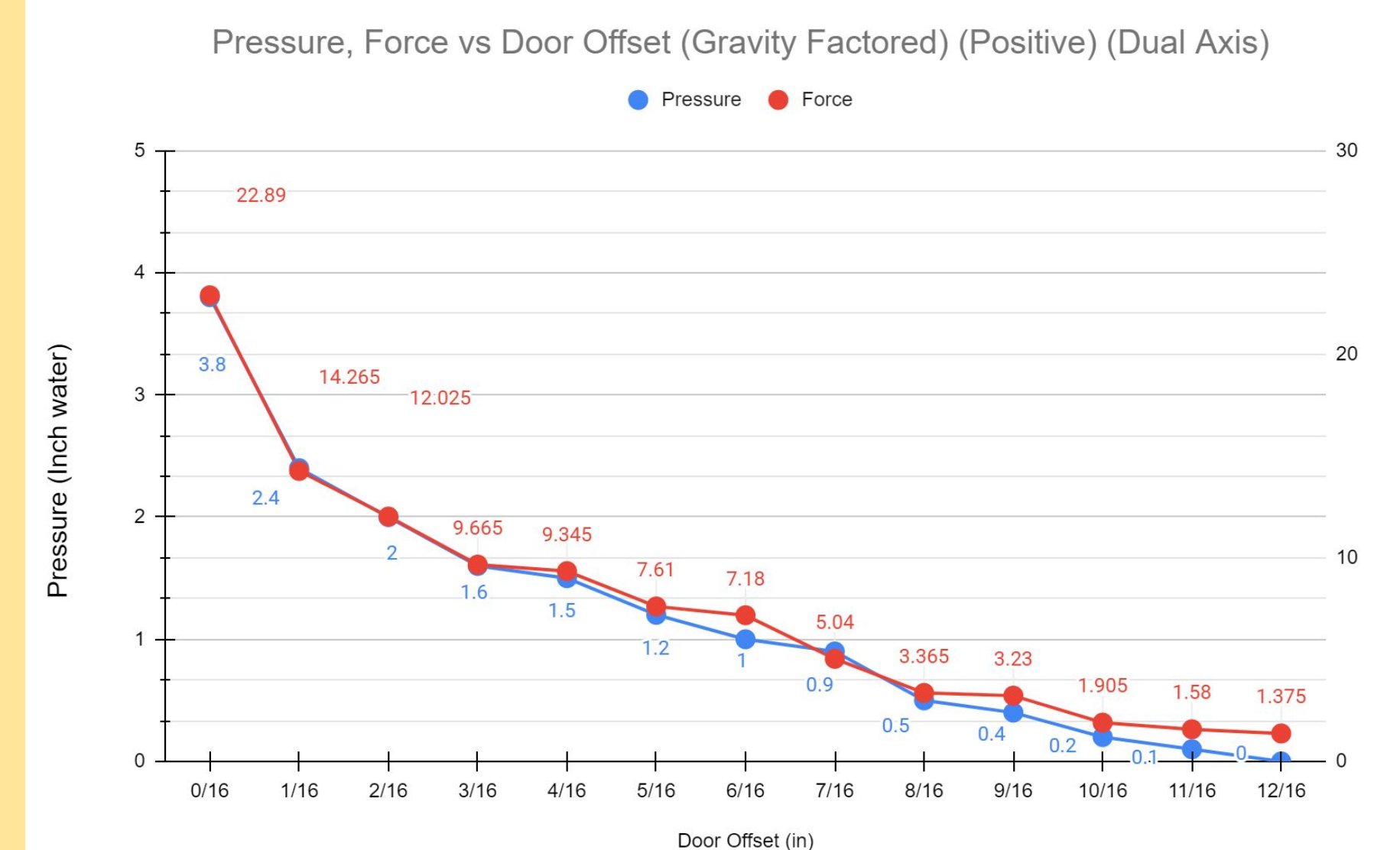

**Positive Pressure**  
22.28 lb Force (Push) for 3.8 inch H<sub>2</sub>O

**Negative Pressure**  
20.3 lb Force (Pull) for 3.7 inch H<sub>2</sub>O

### Experimental Overview

Testing was performed with an 8.8 in H<sub>2</sub>O static-pressure blower and a custom wooden testing rig built by the SDSU Team. A full scale door was constructed to simulate realistic operating conditions (force/pressure) whilst a 1/8th scale volume was held to save space and cost. Force and pressure values were collected at 1/16th door offset intervals using a digital manometer and force gauge; force and pressure were plotted vs distance of door opening. It should be noted that gravity was also factored into the data due to the orientation of the door on the testing rig.

## Final Product

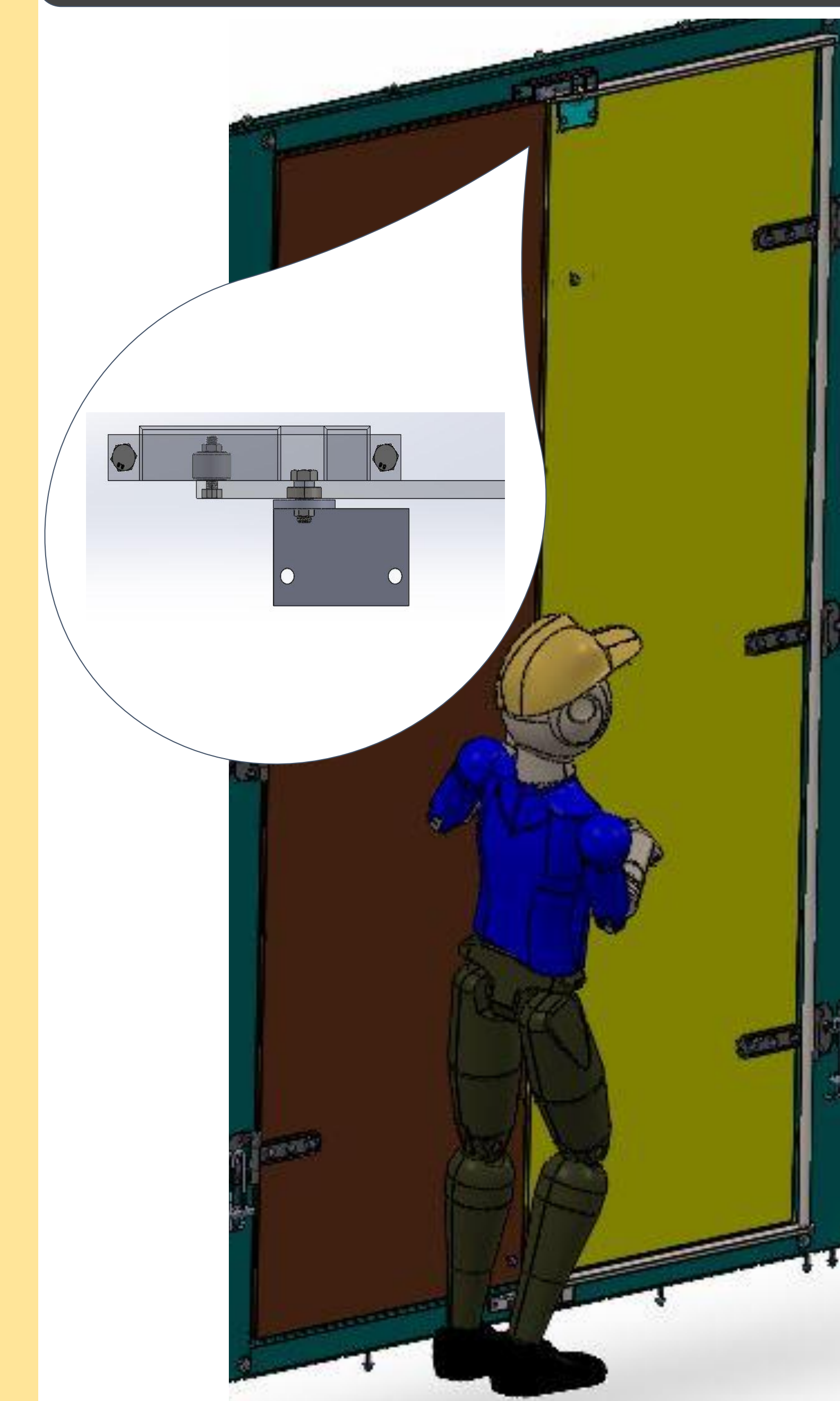

## Acknowledgements

Role	Name
Program Coordinator	Dr. S. Shaffar
Fluid Dynamics Advisor	Dr. A. Lehman
Sponsor Manager	Gregor Robertson
Sponsor Subject Matter Expert	Marco Vagani
Sponsor Advisors	Jordan Ferreira, Kristopher Schaffer
Machine Shop Manager	Michael Lester
Welding Mentor	Carlos Verdeja